

BPT BOX R

Caja con ventilador centrífugo a reacción de baja presión, de doble aspiración a transmisión
Noise isolated cabinet, double inlet belt drive, impeller with backward curved blades
Caisson de ventilation insonorisé à ventilateur centrifuge basse pression
Lüftungsbox



Caja de ventilación completa, compuesta de ventilador anclado sobre soportes antivibratorios, motor fijado sobre bancada regulable, poleas y correas dimensionadas acorde a las prestaciones, aislamiento interno y junta elástica entre boca ventilador y boca impulsión de la caja.

Aplicaciones: Grandes instalaciones de climatización y ventilación.

Noise isolated cabinet fan with double inlet backward wheel. Composed of fan on antivibration mounting, motor, belts and pulley upon required working point.

Applications: Extract or intake of large airflow with high pressure for shopping centres, hospitals, airports, public places.

Caisson de ventilation composé d'un ventilateur ancré sur un support anti-vibration. Moteur fixé sur socle réglable, dimension des poulies et courroies adaptés aux prestations. Isolation thermo acoustique. Jonction élastique entre caisson et bouche de ventilation interne.

Applications: Convient aux installations nécessitant de fort débit et pression en extraction ou insufflation. Grandes installations de ventilation: centres commerciaux, aéroport, centres hospitaliers.

Preisgünstige Ventilatoreinheit mit Motor und Keilriemenantrieb. Mit Laufrad und Gehäuse aus verzinktem Stahlblech.

Anwendungen: Lüftung und Klima, für große Luftmengen, auch bei langen Rohrsystemen oder auch für höhere Widerstände in Maschinen und Aggregaten.

CARACTERÍSTICAS / CHARACTERISTICS / CARACTERISTIQUES / EIGENSCHAFTEN

- Caja de chapa galvanizada, aislada interiormente mediante panel ignífugo clase M1.
 - Rodete, álabes hacia atrás, en chapa galvanizada.
 - Motores con aislamiento clase F y protección IP55.
- OPCIONES:
- Previa consulta pueden servirse para tensiones, frecuencias, regímenes de vueltas distintas y/o motores de doble velocidad.
- Casing of galvanised metal sheet. Insulation panel fire resist class M1.
 - Backward curved wheel of galvanised metal sheet.
 - Motor class F, protection IP55.
- OPTIONS:
- Different tensions, speed and frequencies, 2 speed motors.
- Caisson en tôle d'acier galvanisée équipé de panneaux thermo acoustique de classe M1 (ignifugé).
 - Turbine, aubes vers l'arrière, en tôle galvanisée.
 - Moteurs avec isolation classe F et protection IP55.
- OPTIONS:
- Plusieurs fréquences, tensions et régimes de rotation. Moteur 2 vitesses.
- Gehäuse aus verzinktem Stahlblech. Isolierung aus feuerfestem Panel Klasse M1.
 - Rückwärtsgekrümmtes Radiallaufrad aus verzinktem Stahlblech.
 - Motor Feuchtraumausführung, Schutzart IP55.
- AUF ANFRAGE:
- Sonderspannungen oder -frequenzen, andere Umdrehungen oder 2-stufige Motoren.

		Ø mm	A	kW	ACCESORIOS / ACCESSORIES ACCESSOIRES / ZUBEHÖR			
					BPTE	FI	VA/VI	VS
BPT BOX R 180/4T 0,37kW	BPTBR001	180	1,30	0,37	•	•	•	•
BPT BOX R 180/4T 0,55kW	BPTBR002	180	1,60	0,55	•	•	•	•
BPT BOX R 180/4T 0,75kW	BPTBR003	180	2,20	0,75	•	•	•	•
BPT BOX R 180/4T 1,1kW	BPTBR004	180	2,90	1,10	•	•	•	•
BPT BOX R 180/4T 1,5kW	BPTBR005	180	3,65	1,50	•	•	•	•
BPT BOX R 180/4T 2,2kW	BPTBR006	180	5,05	2,20	•	•	•	•
BPT BOX R 225/4T 0,37kW	BPTBR010	225	1,30	0,37	•	•	•	•
BPT BOX R 225/4T 0,55kW	BPTBR011	225	1,60	0,55	•	•	•	•
BPT BOX R 225/4T 0,75kW	BPTBR012	225	2,20	0,75	•	•	•	•
BPT BOX R 225/4T 1,1kW	BPTBR013	225	2,90	1,10	•	•	•	•
BPT BOX R 225/4T 1,5kW	BPTBR013	225	3,65	1,50	•	•	•	•
BPT BOX R 225/4T 2,2kW	BPTBR014	225	5,05	2,20	•	•	•	•
BPT BOX R 225/4T 3,0kW	BPTBR015	225	6,60	3,00	•	•	•	•
BPT BOX R 225/4T 4,0kW	BPTBR016	225	9,40	4,00	•	•	•	•
BPT BOX R 250/4T 0,37kW	BPTBR020	250	1,30	0,37	•	•	•	•
BPT BOX R 250/4T 0,55kW	BPTBR021	250	1,60	0,55	•	•	•	•
BPT BOX R 250/4T 0,75kW	BPTBR022	250	2,20	0,75	•	•	•	•
BPT BOX R 250/4T 1,1kW	BPTBR023	250	2,90	1,10	•	•	•	•
BPT BOX R 250/4T 1,5kW	BPTBR024	250	3,65	1,50	•	•	•	•
BPT BOX R 250/4T 2,2kW	BPTBR025	250	5,05	2,20	•	•	•	•
BPT BOX R 250/4T 3,0kW	BPTBR026	250	6,60	3,00	•	•	•	•
BPT BOX R 250/4T 4,0kW	BPTBR027	250	9,40	4,00	•	•	•	•

ACCESORIOS / ACCESSORIES / ACCESSOIRES / ZUBEHÖR

■ Accesorios equipos / Accessories equipments
Accessoires équipements / Zubehör Wärmetauschereinheiten



BPTE (pg. 551)



FI (pg. 552)



VA (pg. 553)



VI (pg. 554)



VS (pg. 555)

CARACTERÍSTICAS / CHARACTERISTICS / CARACTERISTIQUES / EIGENSCHAFTEN

		Ø mm	A	kW	ACCESORIOS / ACCESSORIES ACCESSOIRES / ZUBEHÖR			
					BPTE	FI	VA/VI	VS
BPT BOX R 315/4T 0,75kW	BPTBR030	315	2,20	0,75	•	•	•	•
BPT BOX R 315/4T 1,1kW	BPTBR031	315	2,90	1,10	•	•	•	•
BPT BOX R 315/4T 1,5kW	BPTBR032	315	3,65	1,50	•	•	•	•
BPT BOX R 315/4T 2,2kW	BPTBR033	315	5,05	2,20	•	•	•	•
BPT BOX R 315/4T 3,0kW	BPTBR034	315	6,60	3,00	•	•	•	•
BPT BOX R 315/4T 4,0kW	BPTBR035	315	9,40	4,00	•	•	•	•
BPT BOX R 315/4T 5,5kW	BPTBR036	315	12,14	5,50	•	•	•	•
BPT BOX R 400/4T 1,1kW	BPTBR040	400	2,90	1,10	•	•	•	•
BPT BOX R 400/4T 1,5kW	BPTBR041	400	3,65	1,50	•	•	•	•
BPT BOX R 400/4T 2,2kW	BPTBR042	400	5,05	2,20	•	•	•	•
BPT BOX R 400/4T 3,0kW	BPTBR043	400	6,60	3,00	•	•	•	•
BPT BOX R 400/4T 4,0kW	BPTBR044	400	9,40	4,00	•	•	•	•
BPT BOX R 400/4T 5,5kW	BPTBR045	400	12,14	5,50	•	•	•	•
BPT BOX R 400/4T 7,5kW	BPTBR046	400	16,90	7,50	•	•	•	•
BPT BOX R 450/4T 1,1kW	BPTBR050	450	2,90	1,10	•	•	•	•
BPT BOX R 450/4T 1,5kW	BPTBR051	450	3,65	1,50	•	•	•	•
BPT BOX R 450/4T 2,2kW	BPTBR052	450	5,05	2,20	•	•	•	•
BPT BOX R 450/4T 3,0kW	BPTBR053	450	6,60	3,00	•	•	•	•
BPT BOX R 450/4T 4,0kW	BPTBR054	450	9,40	4,00	•	•	•	•
BPT BOX R 450/4T 5,5kW	BPTBR055	450	12,14	5,50	•	•	•	•
BPT BOX R 450/4T 7,5kW	BPTBR056	450	16,90	7,50	•	•	•	•
BPT BOX R 450/4T 11kW	BPTBR057	450	22,60	11,00	•	•	•	•
BPT BOX R 500/4T 2,2kW	BPTBR060	500	5,05	2,20	•	•	•	•
BPT BOX R 500/4T 3,0kW	BPTBR061	500	6,60	3,00	•	•	•	•
BPT BOX R 500/4T 4,0kW	BPTBR062	500	9,40	4,00	•	•	•	•
BPT BOX R 500/4T 5,5kW	BPTBR063	500	12,14	5,50	•	•	•	•
BPT BOX R 500/4T 7,5kW	BPTBR064	500	22,60	11,00	•	•	•	•
BPT BOX R 500/4T 11kW	BPTBR065	500	31,00	15,00	•	•	•	•
BPT BOX R 560/4T 3,0kW	BPTBR070	560	6,60	3,00	•	•	•	•
BPT BOX R 560/4T 4,0kW	BPTBR071	560	9,40	4,00	•	•	•	•
BPT BOX R 560/4T 5,5kW	BPTBR072	560	12,14	5,50	•	•	•	•
BPT BOX R 560/4T 7,5kW	BPTBR073	560	16,90	7,50	•	•	•	•
BPT BOX R 560/4T 11kW	BPTBR074	560	22,60	11,00	•	•	•	•
BPT BOX R 560/4T 15W	BPTBR075	560	31,00	15,00	•	•	•	•
BPT BOX R 630/4T 3,0kW	BPTBR080	630	6,60	3,00	•	•	•	•
BPT BOX R 630/4T 4,0kW	BPTBR081	630	9,40	4,00	•	•	•	•
BPT BOX R 630/4T 5,5kW	BPTBR082	630	12,14	5,50	•	•	•	•
BPT BOX R 630/4T 7,5kW	BPTBR083	630	16,90	7,50	•	•	•	•
BPT BOX R 630/4T 11kW	BPTBR084	630	22,60	11,00	•	•	•	•
BPT BOX R 630/4T 15kW	BPTBR085	630	31,00	15,00	•	•	•	•
BPT BOX R 800/4T 3,0kW	BPTBR090	800	6,60	3,00	•	•	•	•
BPT BOX R 800/4T 4,0kW	BPTBR091	800	9,40	4,00	•	•	•	•
BPT BOX R 800/4T 5,5kW	BPTBR092	800	12,14	5,50	•	•	•	•
BPT BOX R 800/4T 7,5kW	BPTBR093	800	16,90	7,50	•	•	•	•
BPT BOX R 800/4T 11kW	BPTBR094	800	22,60	11,00	•	•	•	•
BPT BOX R 800/4T 15kW	BPTBR095	800	31,00	15,00	•	•	•	•

DIMENSIONES / DIMENSIONS / DIMENSIONS / ABMESSUNGEN (mm)

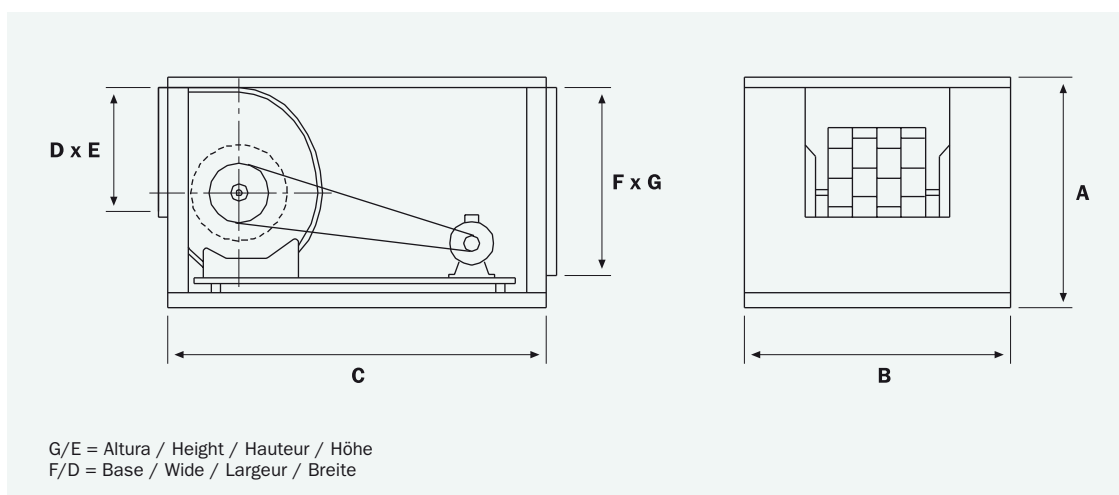

	A	B	C	D x E	F x G	H	Kg ¹
BPT BOX R 180	430	500	625	229 x 229	378 x 349	30	45
BPT BOX R 225	460	550	700	288 x 288	408 x 400	30	55
BPT BOX R 250	515	600	750	322 x 322	463 x 449	30	70
BPT BOX R 315	595	700	850	404 x 404	543 x 549	30	90
BPT BOX R 400	695	850	1.000	507 x 507	643 x 609	30	110
BPT BOX R 450	825	1.000	1.172	569 x 569	773 x 649	30	150
BPT BOX R 500	1.162	1.098	1.409	638 x 638	1.005 x 832	30	285
BPT BOX R 560	1.347	1.189	1.568	715 x 715	1.096 x 1.019	30	315
BPT BOX R 630	1.500	1.325	1.703	801 x 801	1.232 x 1.089	30	355
BPT BOX R 800	1.695	1.523	1.936	1.007 x 1.007	1.429 x 1.185	30	480

¹ Versión con motor más potente
 Versión with powerful motor
 Version avec moteurs plus puissants
 Ausführung mit stärkerem Motor

ACCESORIOS / ACCESSORIES / ACCESSOIRES / ZUBEHÖR

■ **Accesorios equipos / Accessories equipments**
Accessoires équipements / Zubehör Wärmetauschereinheiten

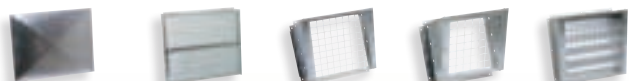

BPT E (pg. 551) **FI** (pg. 552) **VA** (pg. 553) **VI** (pg. 554) **VS** (pg. 555)

CURVAS CARACTERÍSTICAS / PERFORMANCE DATA / COURBES / KENNLINIEN

BPT BOX R 180

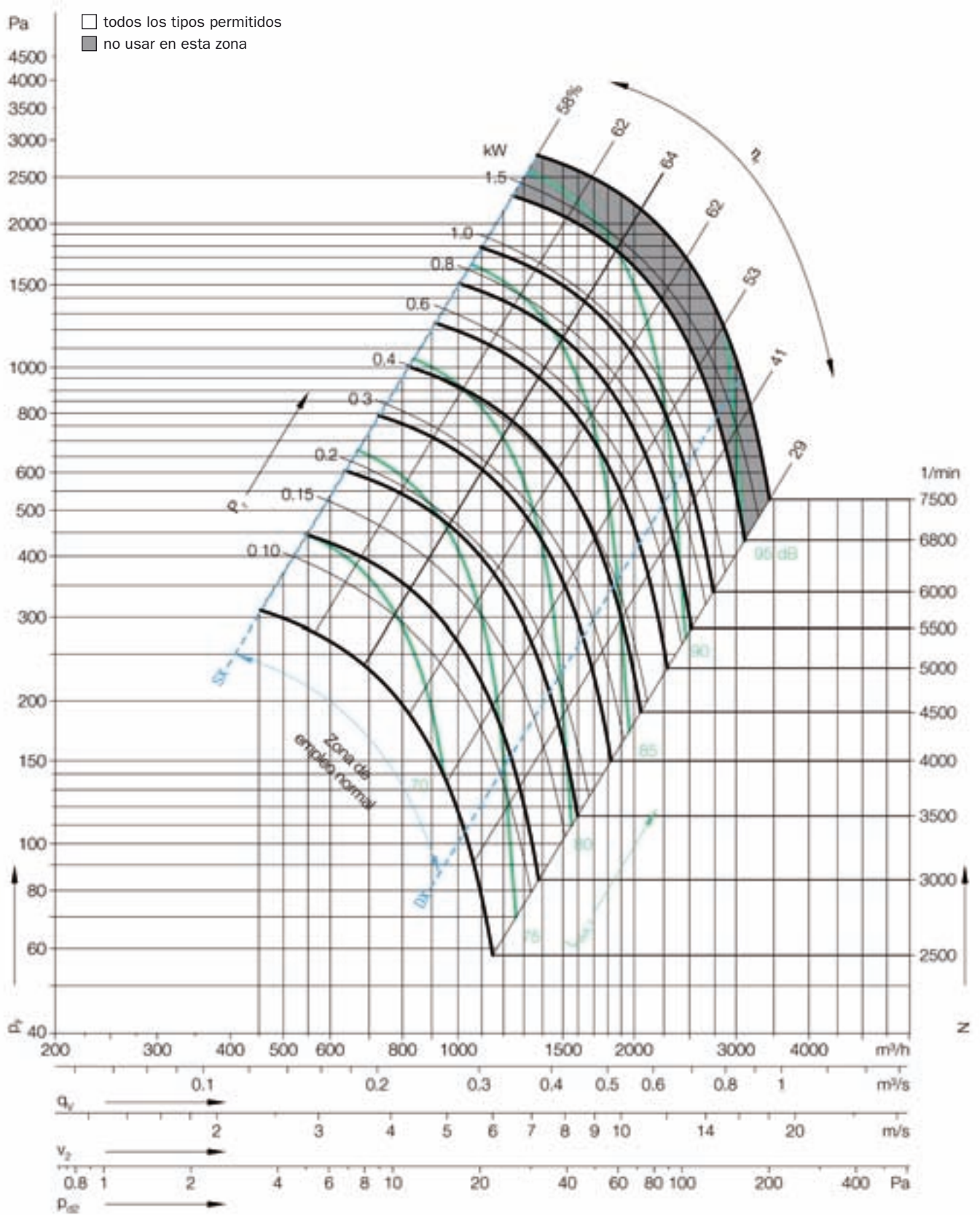

CURVAS CARACTERÍSTICAS / PERFORMANCE DATA / COURBES / KENNLINIEN

BPT BOX R 225

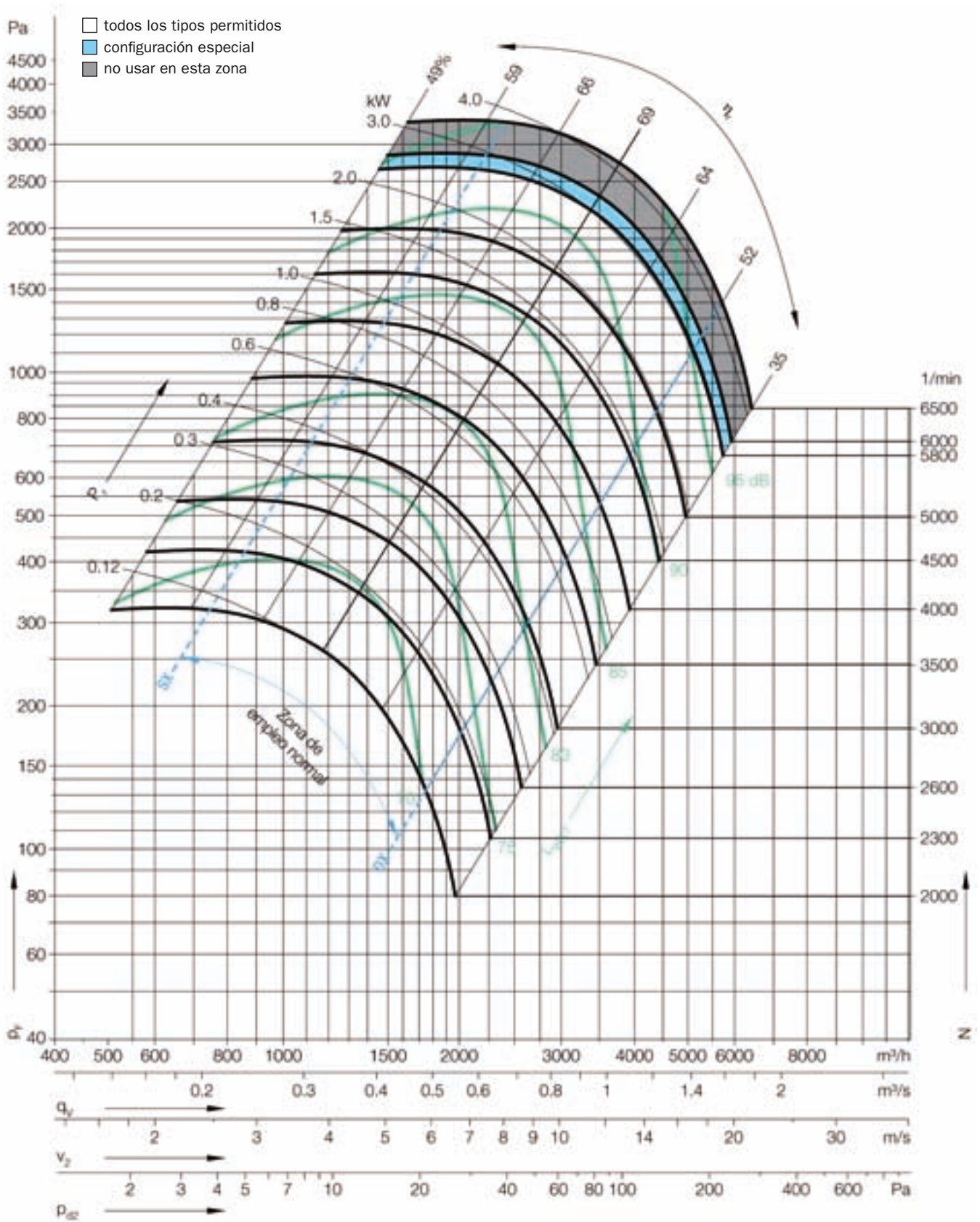

CURVAS CARACTERÍSTICAS / PERFORMANCE DATA / COURBES / KENNLINIEN

BPT BOX R 250

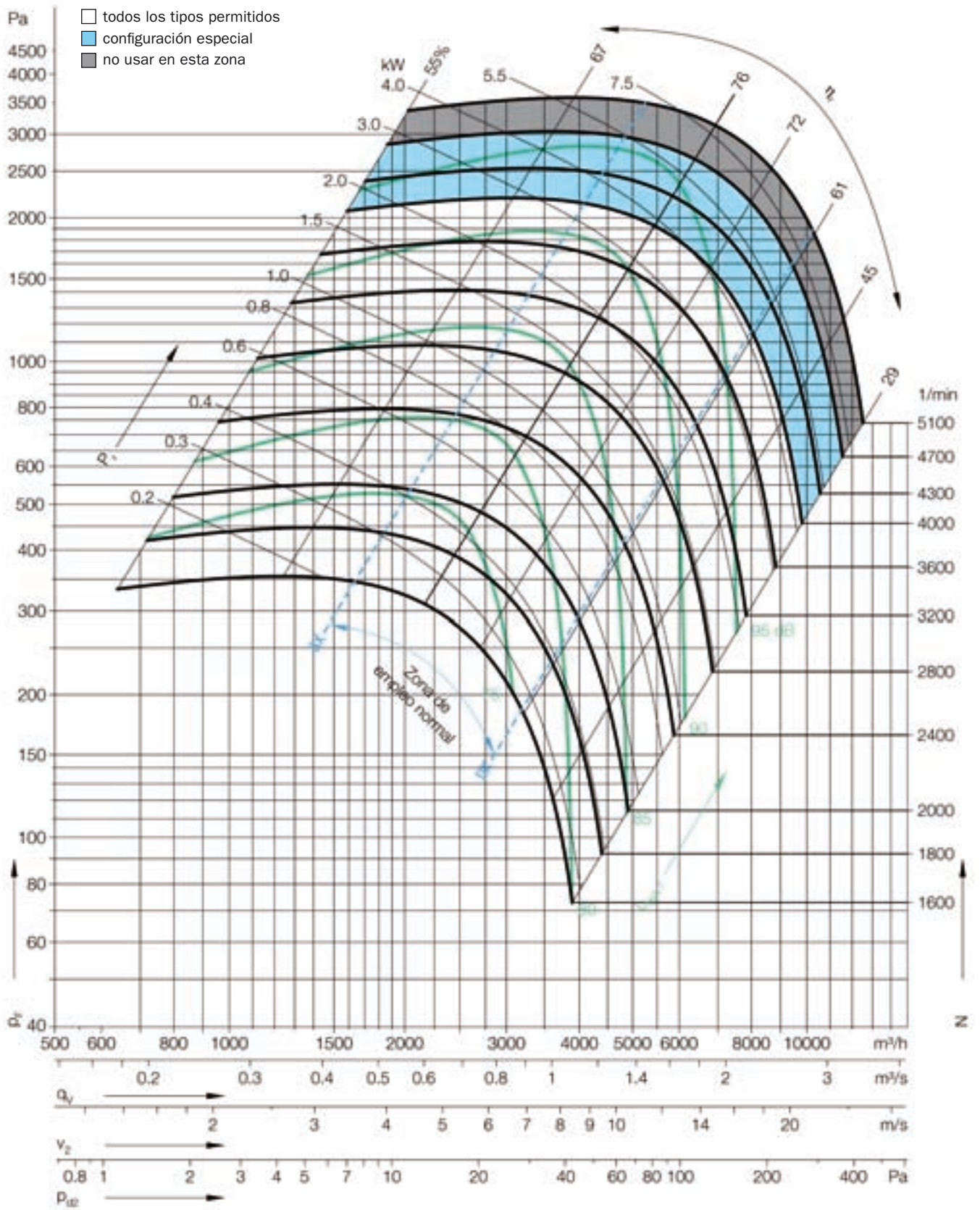

CURVAS CARACTERÍSTICAS / PERFORMANCE DATA / COURBES / KENNLINIEN

BPT BOX R 315

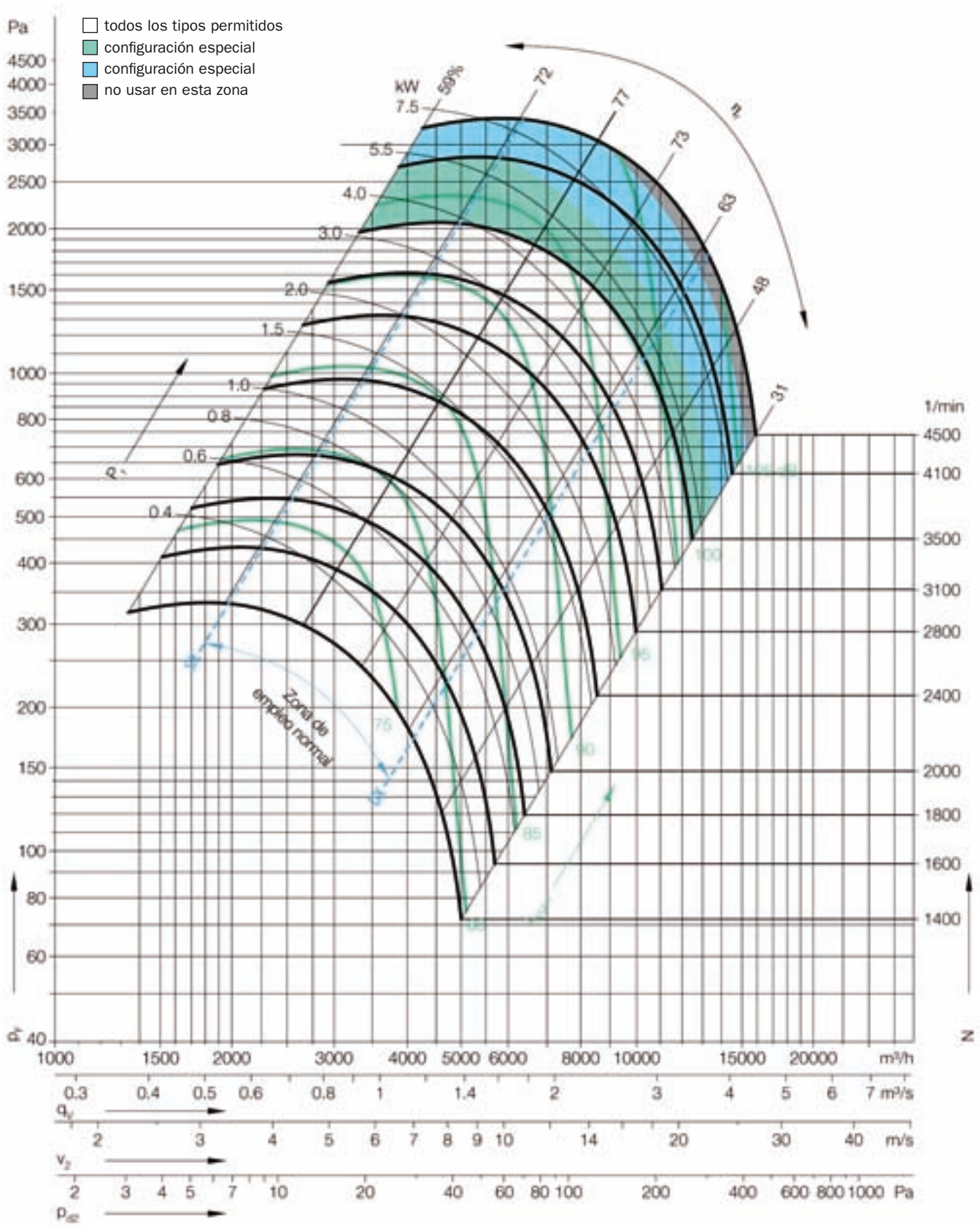

CURVAS CARACTERÍSTICAS / PERFORMANCE DATA / COURBES / KENNLINIEN

BPT BOX R 400

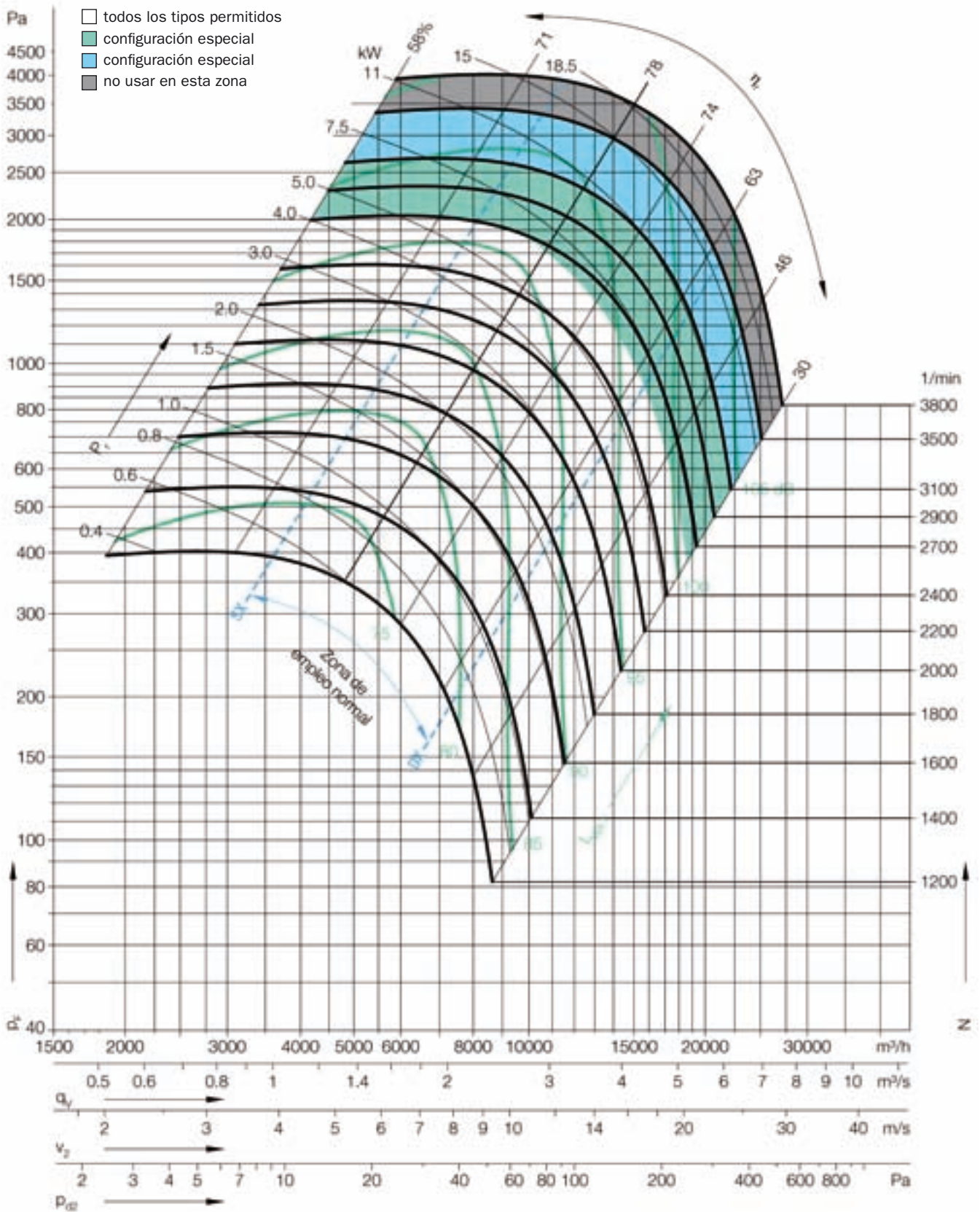

CURVAS CARACTERÍSTICAS / PERFORMANCE DATA / COURBES / KENNLINIEN

BPT BOX R 450

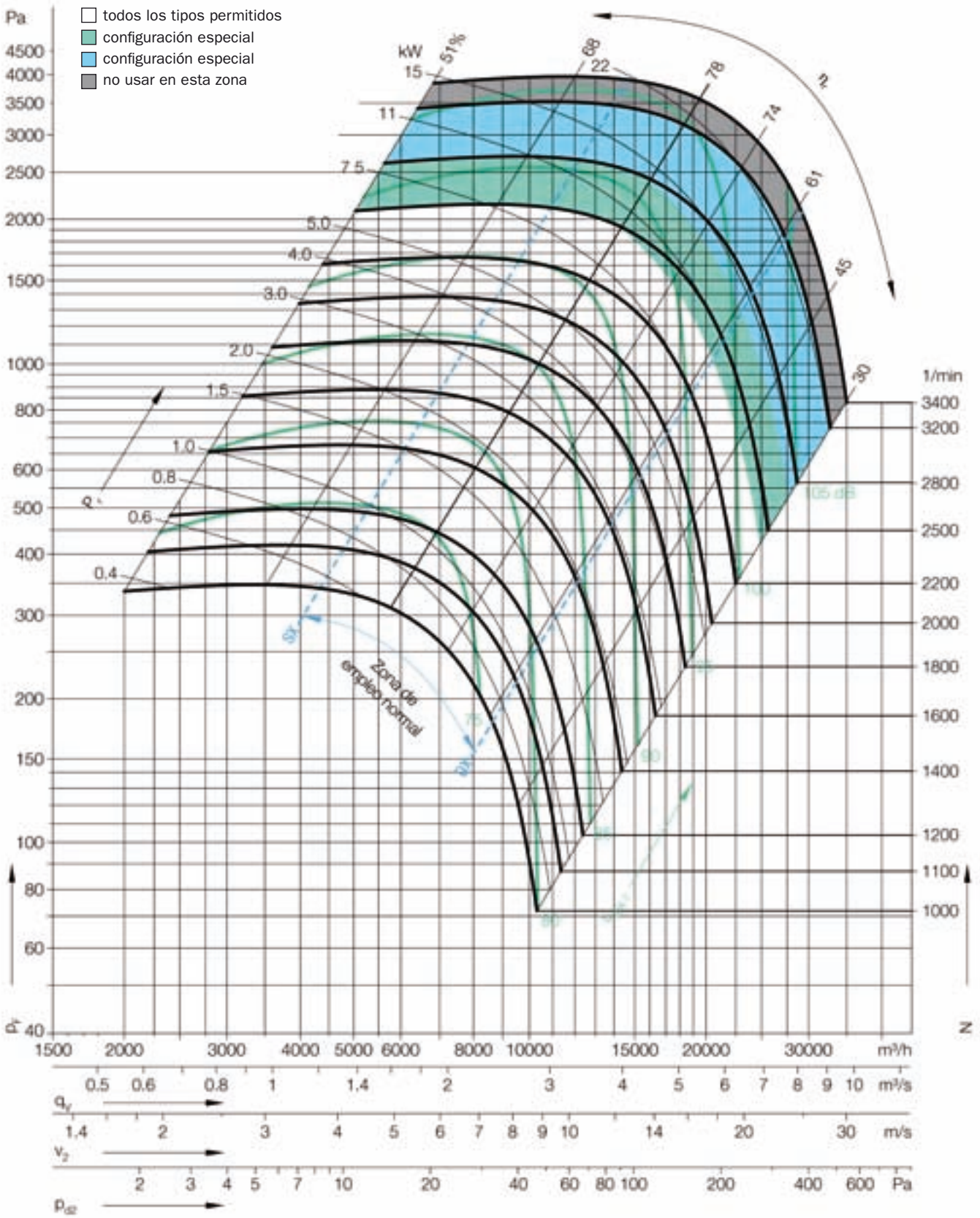

CURVAS CARACTERÍSTICAS / PERFORMANCE DATA / COURBES / KENNLINIEN

BPT BOX R 500

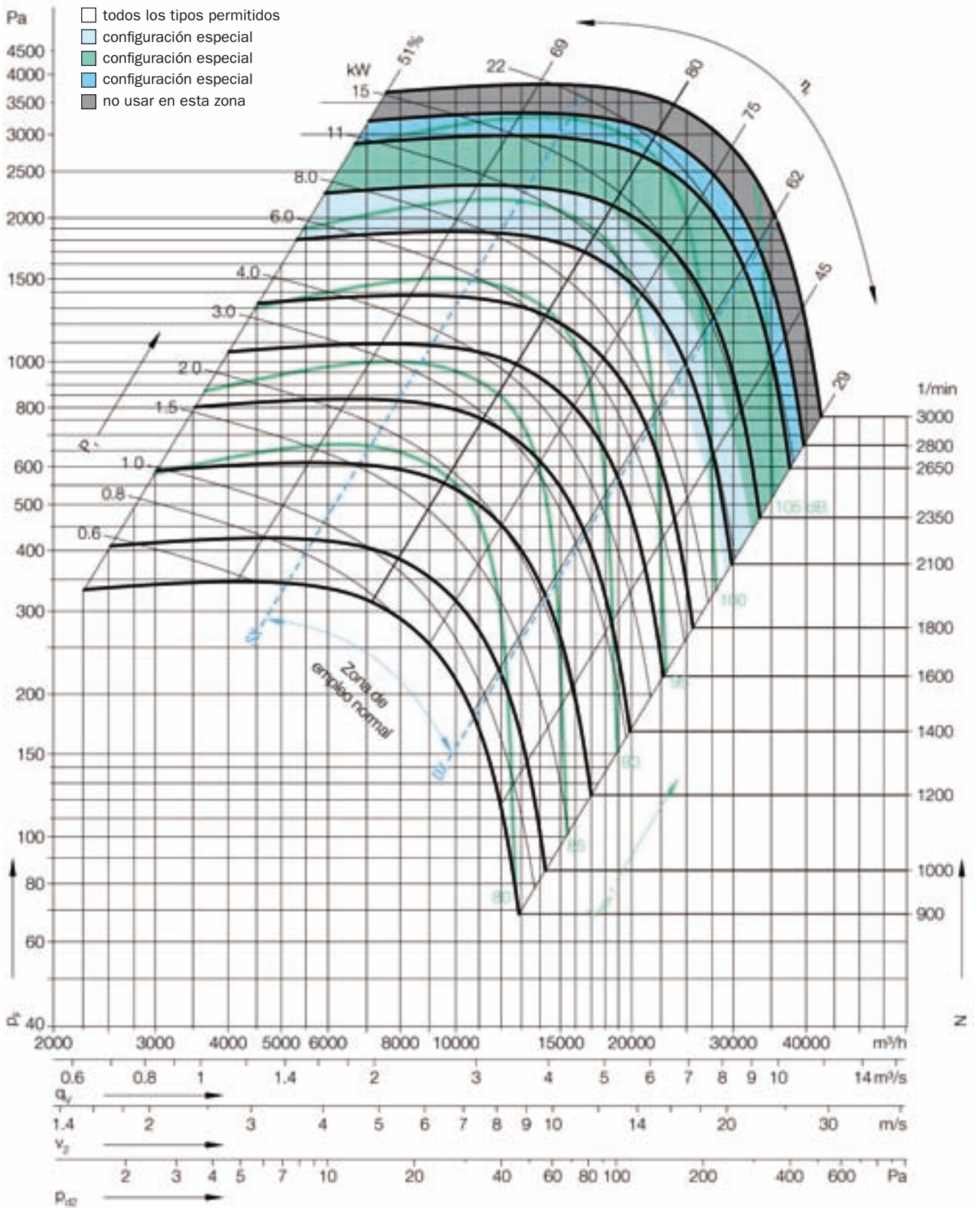

CURVAS CARACTERÍSTICAS / PERFORMANCE DATA / COURBES / KENNLINIEN

BPT BOX R 560

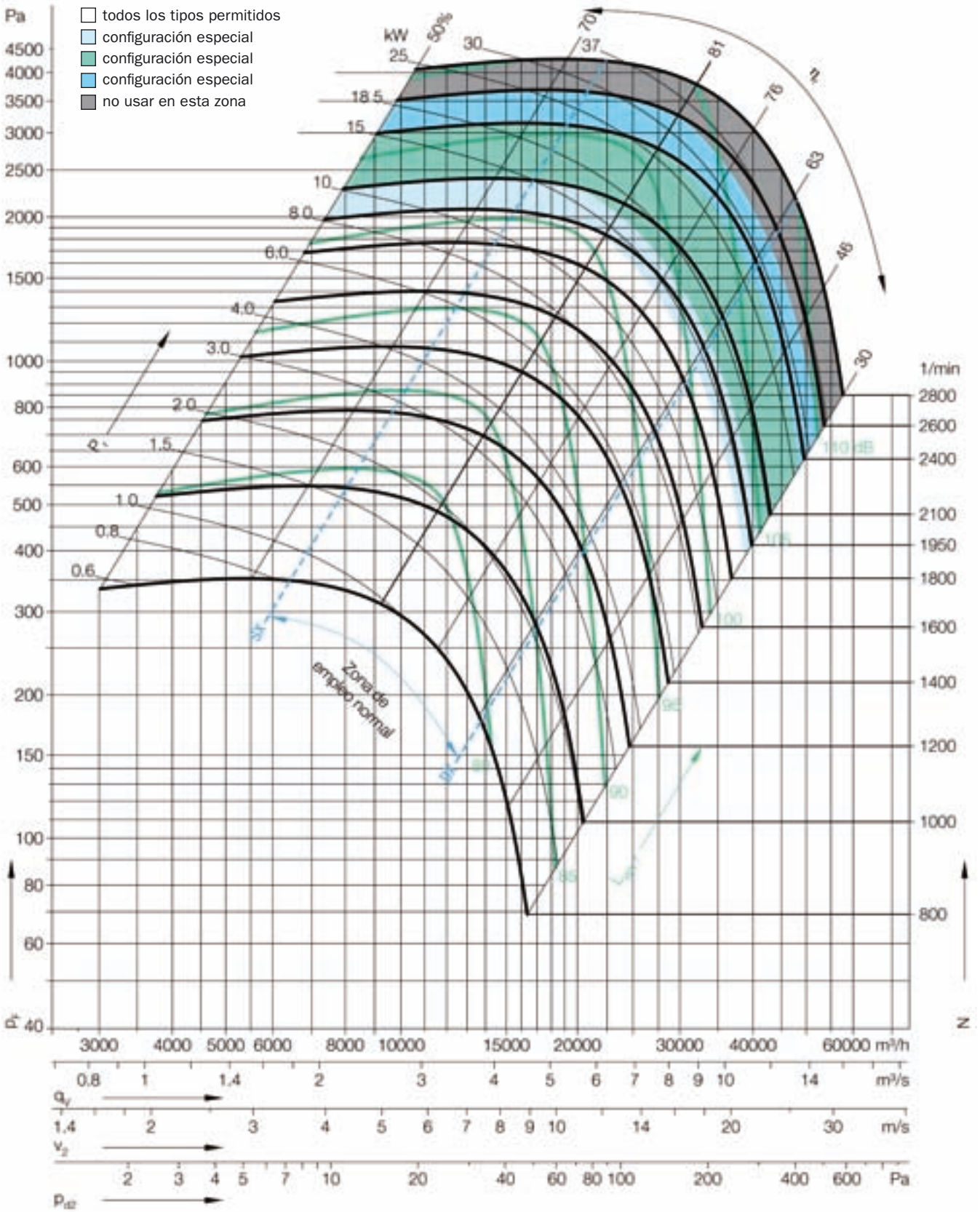

CURVAS CARACTERÍSTICAS / PERFORMANCE DATA / COURBES / KENNLINIEN

BPT BOX R 630

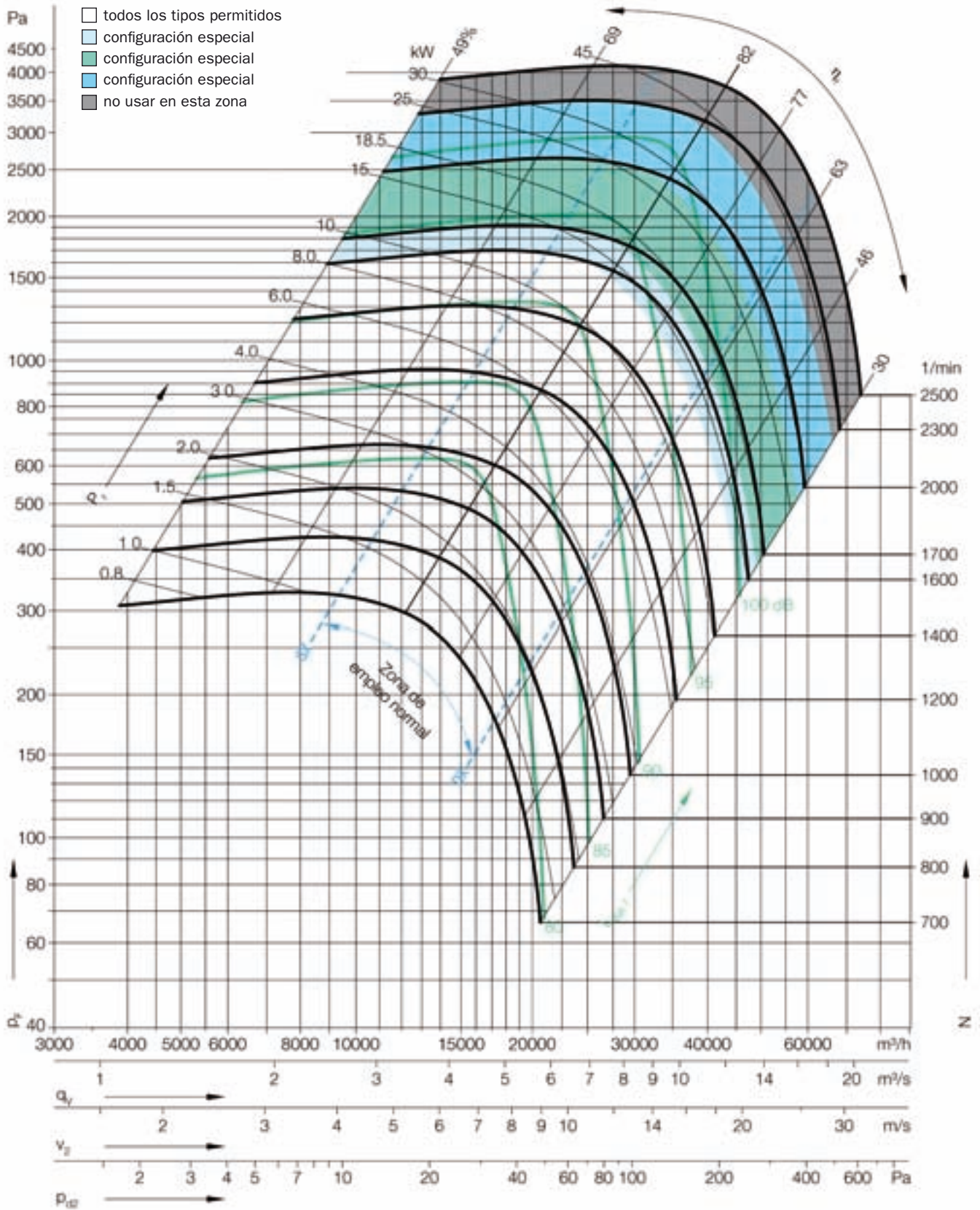

CURVAS CARACTERÍSTICAS / PERFORMANCE DATA / COURBES / KENNLINIEN

BPT BOX R 800

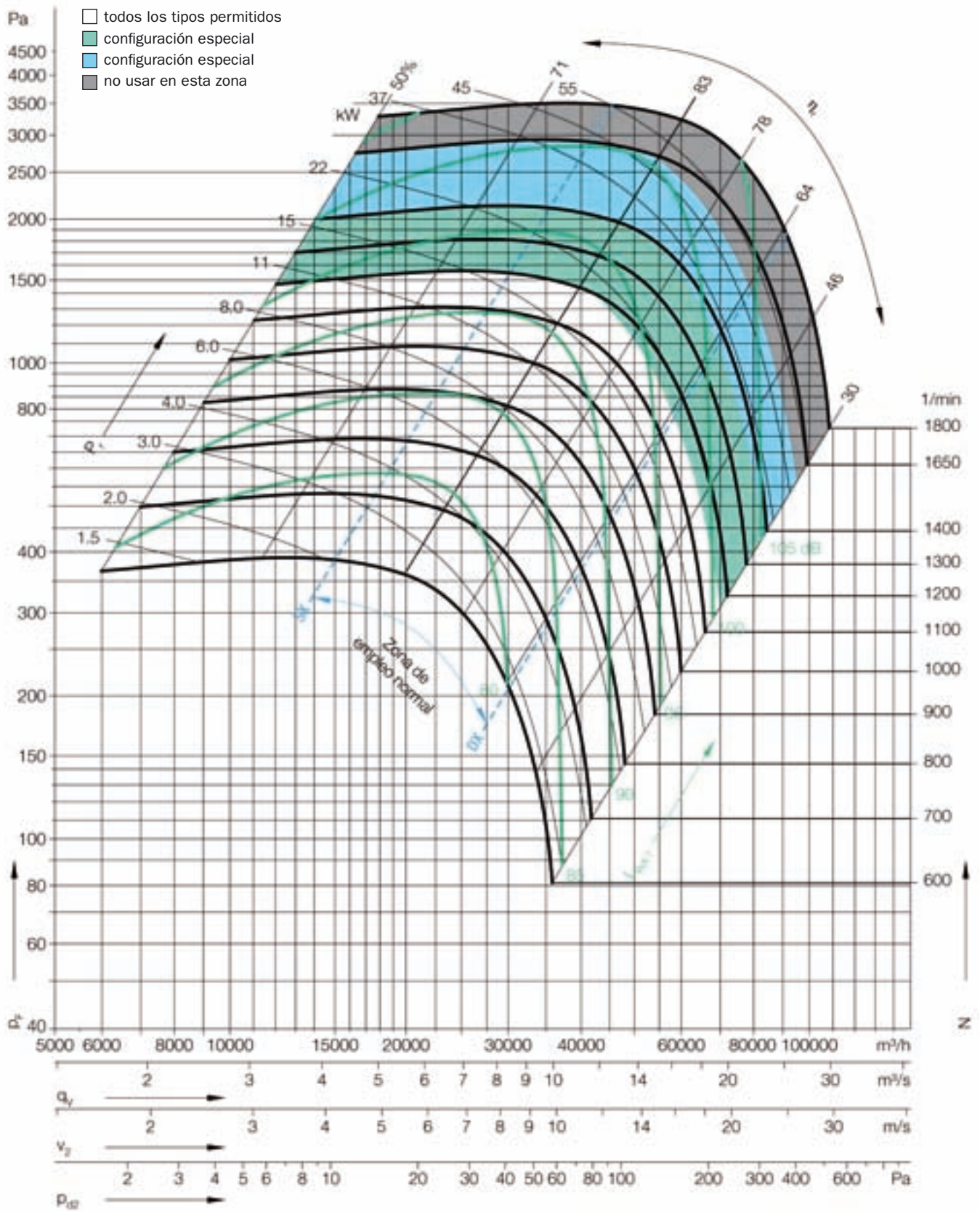

EJEMPLO DE SELECCIÓN DE EQUIPO

Caudal 9.000 m³/h
Pest 1.250 Pa

Si seleccionamos una **BPT BOX R 400**

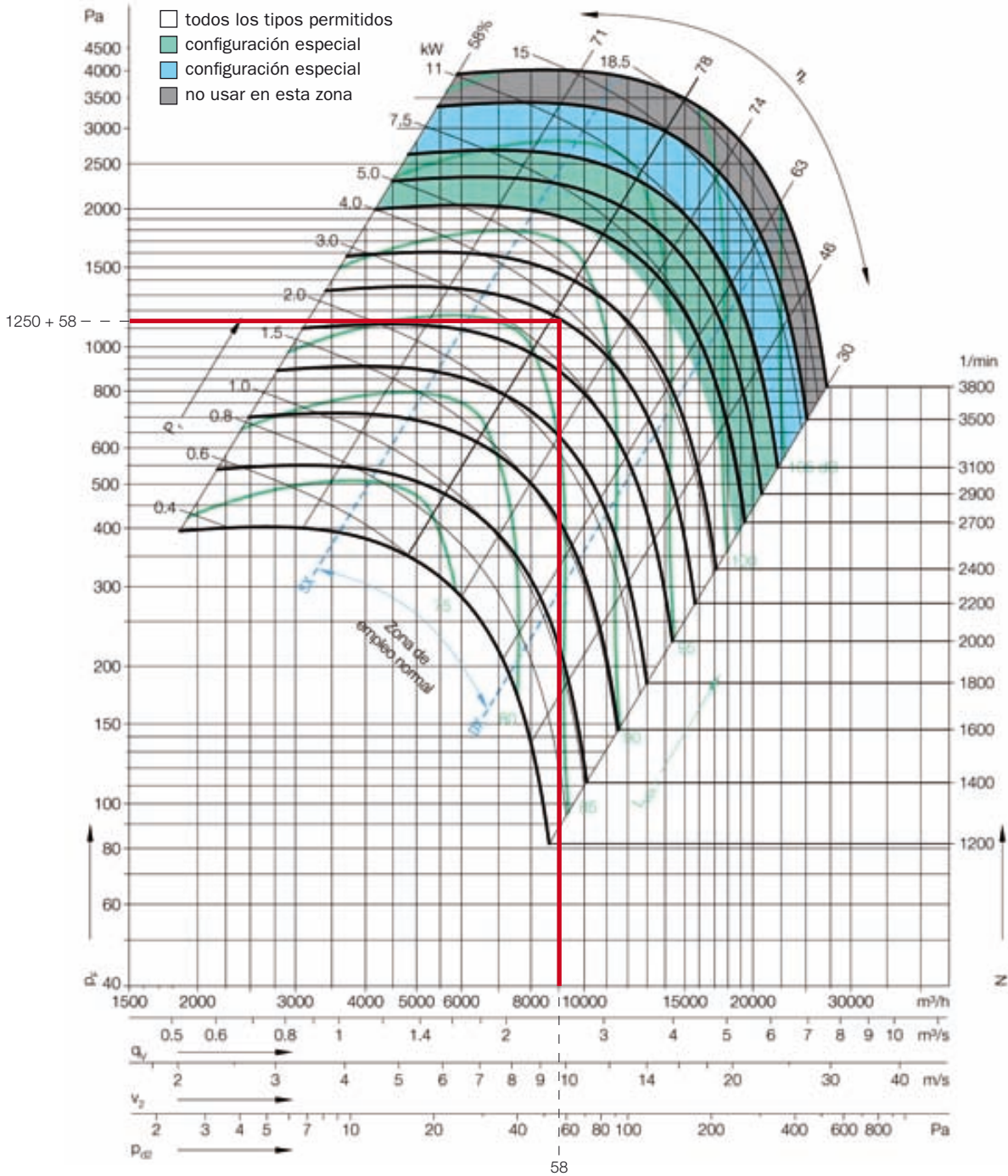

La intersección del punto de trabajo es a:

Revoluciones	2.200 rpm
Potencia absorbida en el eje	3,7 kW
Potencia Mínima motor	$3,7 / 0,85 = 4,3^* \text{ kW}$
Potencia Motor	5,5 kW

EQUIPO: BPT BOX R 400/4T 5,5 kW 2.200 rpm

* Se considera un 15% debido al rendimiento del motor más las pérdidas originadas en las transmisiones